

NEW!

ENGINE

Model	: ISUZU AR-4HK1X
Type	: Water cooled diesel engine, 4 cycles, 4 cylinders, line-type, direct injection, turbocharger and intercooler
Power	: 172 HP (128 kW) @2000 rpm / SAE J1995 (Gross) : 162 HP (120 kW) @2000 rpm / SAE J1349 (Net)
Max. Torque	: 670 Nm @1600 rpm (Gross) : 649 Nm @1600 rpm (Net)
Displacement	: 5193 cc
Bore and Stroke	: 115 mm x 125 mm

This new engine complies with the Emission Regulations U.S EPA Tier 4 Final and EU Stage IV

LOWER STRUCTURE (CHASSIS)

Chassis	: Box shaped, reinforced lower chassis, front dozer blade and rear outriggers (stabilizers) as standard figures.
Axles	: The pivot pin mounted front axle allows two options: 8° in each direction for best matching conditions, or could be locked at any desired position for perfect stability.
Tires	: 11,00 - 20 (16 pr)

CAB

- Improved operator's all round visibility
- Increased cabin internal space
- Use of six viscomount cabin mountings that dampen the vibrations
- High capacity A/C
- 8" touch TFT screen
- Opera Control System
- Cooled storage room
- Glass holder, book and object storage pockets
- Pool type floor mat
- Improved operator's comfort through versatile adjustable seat

STEERING SYSTEM

The "orbital" type steering system controls a steering cylinder located on the front axle. Minimum turning radius is 6.800 mm.

TRAVEL AND BRAKERS

Travel	: Fully hydrostatic
Travel Motors	: Axial piston type
Reduction	: 2 stage planetary gear
Travel Speed	
High Speed	: 31 km/h
Low Speed	: 7,7 km/h
Max. Drawbar Pull	: 11.110 kgf
Gradeability	: 29° (%55)
Parking Brake	: Hydraulic, disc type with automatic warning
Service Brake	: Fully hydraulically operating disc type brakes with spring return, independent for front and rear axles.

LUBRICATION

Centralized lubrication system is provided for lubrication all difficult-to-reach parts on the components, such as boom and arm

HYDRAULIC SYSTEM

Main Pump	
Type	: 2 axial piston type pumps with double variable displacement and inclined plate
Max. Flow Rate	: 2 x 233 L/min
Pilot Pump	: Gear type, 20 L/min
Working Pressures	
Cylinders	: 350 kgf/cm ²
Power Boost	: 370 kgf/cm ²
Travel	: 360 kgf/cm ²
Swing	: 306 kgf/cm ²
Pilot	: 40 kgf/cm ²
Cylinders	
Boom	: 2 x ø 120 x ø 85 x 1.300 mm
Arm	: 1 x ø 135 x ø 95 x 1.520 mm
Bucket	: 1 x ø 120 x ø 85 x 1.060 mm

OPERA CONTROL SYSTEM

- Easy-to-use control panel and menu
- Improved fuel economy and productivity
- Maximum efficiency by selection of power and work modes
- Overheat prevention and protection system without interrupting the work
- Automatic powerboost switch-on and switch-off
- Automatic electric power-off
- Maintenance information and warning system
- Error mode registry and warning system
- Ability to adjust hydraulic flow from Opera screen
- Maintenance information and warning system
- Automatic powershift to improve performance
- Selection of multi-language on control panel.
- Real time monitoring of operational parameters such as pressure, temperature, engine load
- Anti-theft system with personal code
- Possibility to register 27 different operating hours
- Rear-view, arm-view camera (Optional)
- Hidromek Smartlink (Optional)

SWING SYSTEM

Swing Motor	: Axial piston type integrated with shock absorber valves
Reduction	: 2 stage planetary gear box.
Swing Brakes	: Hydraulic multi disc type.
Swing Speed	: 11,90 rpm

FILLING CAPACITIES

Fuel Tank	: 345 L	Engine Oil	: 21 L
Hydraulic Tank	: 160 L	Engine Cooling Sys.	: 33 L
Hydraulic System	: 318 L	Urea	: 16 L

ELECTRICAL SYSTEM

Voltage	: 24V
Battery	: 2 x 12 V x 150 Ah
Alternator	: 24V / 50 A
Starting Motor	: 24V / 5,0 kW

OPERATING WEIGHT

Standard machine operating weight	: 22.500 kg
-----------------------------------	-------------

Operational weight, complying with the ISO 6016 standards, includes full fuel tank, hydraulic system and other liquids, 75kg operator weight and standard equipped machine weight. Optional equipments are not included.

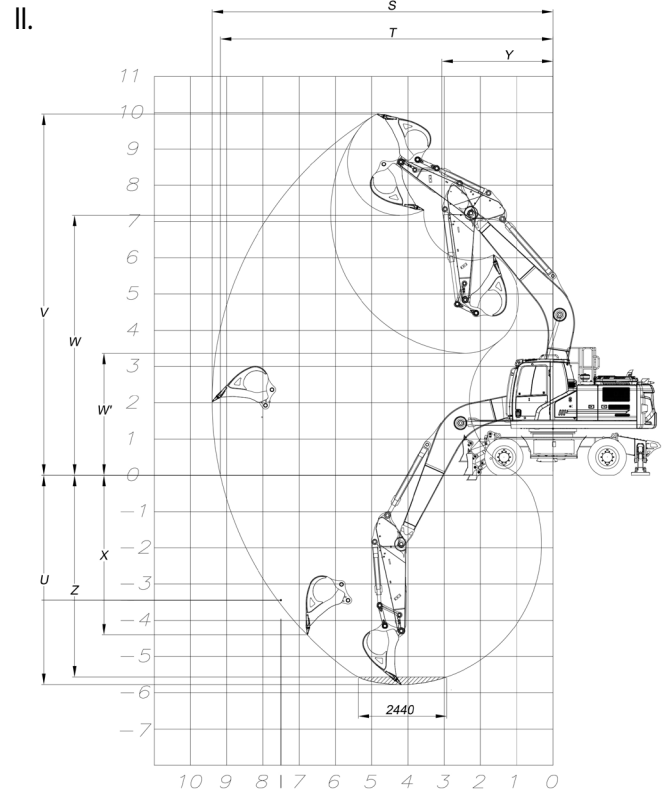
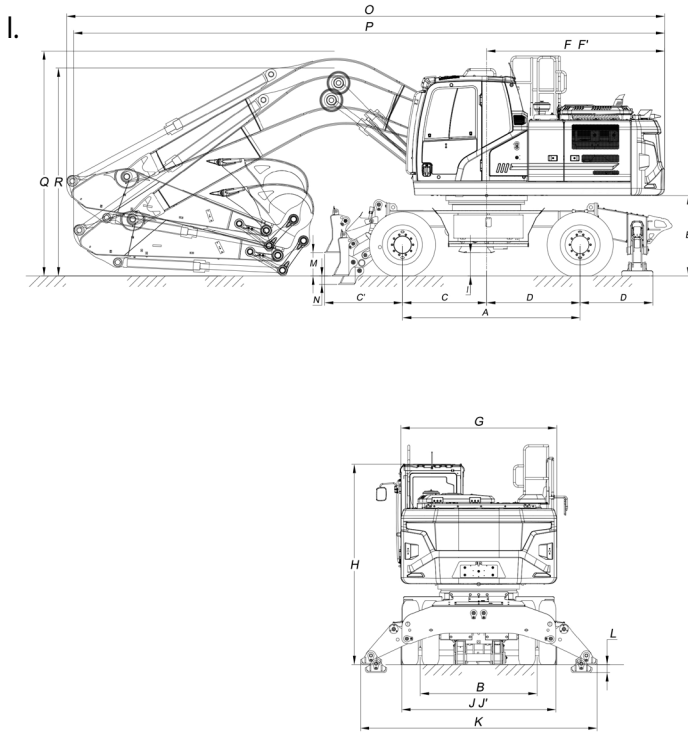

I. GENERAL DIMENSIONS

Boom Dimension	5.600 mm	
Arm Dimension	*2.400 mm	2.920 mm
A - Axle Distance	2.850 mm	
B - Thread	1.910 mm	
C - Rotation Axis – Front Axle Distance	1.500 mm	
C' - Maximum Front Axle - Dozer Distance	1.240 mm	
D - Rotation Axis – Rear Axle Distance	1.350 mm	
D' - Rear Axle - Foot Distance	1.150 mm	
E - Upper Chassis to Ground Clearance	1.290 mm	
F - Counterweight Distance	2.860 mm	
F' - Counterweight Turning Radius	2.890 mm	
G - Upper Frame Width	2.500 mm	
H - Cab Height	3.220 mm	
I - Outrigger Ground Clearance	350 mm	
J - Dozer Blade Width	2.540 mm	
J' - Width at Tires	2.500 mm	
K - Outrigger Width (Overall)	3.780 mm	
L - Outrigger Digging Depth	120 mm	
M - Dozer Blade Ground Clearance	350 mm	
N - Dozer Blade Digging Depth	120 mm	
O - Overall Length/ Transport	9.590 mm	9.610 mm
P - Overall Length / Travel	9.480 mm	9.550 mm
Q - Boom Height / Travel	3.610 mm	3.690 mm
R - Boom Height / Transport	3.270 mm	3.390 mm

* Standard

II. WORKING DIMENSIONS

Boom Dimension	5.600 mm	
Arm Dimension	*2.400 mm	2.920 mm
S - Maximum Digging Reach	9.400 mm	9.790 mm
T - Maximum Digging Reach at Ground Level	9.170 mm	9.570 mm
U - Maximum Digging Depth	5.760 mm	6.280 mm
V - Maximum Digging Height	9.970 mm	10.020 mm
W - Maximum Dumping Clearance	7.110 mm	7.290 mm
W' - Minimum Dumping Clearance	3.370 mm	2.850 mm
X - Maximum Vertical Digging Depth	4.420 mm	4.610 mm
Y - Minimum Swing Radius	3.080 mm	3.050 mm
Z - Maximum Digging Depth (2440 mm level)	5.550 mm	6.090 mm

* Standard

III. DIGGING PERFORMANCE

Standard Bucket Capacity (SAE)	0,9 m ³
Bucket Digging Force (Power Boost) ISO	14.900 (15.800) kgf
Arm Crowd Force (Power Boost) ISO	11.800 (12.500) kgf